

Geschwindigkeiten • Speeds • Vitesses

SR WB 66-125/4		t =	1.5 min	66 kW	400 V	
SR 10-190/3		v = 0 →	25 m / min.	2 x 10.0 kW	50 Hz	
SR WB 150/4		v = 0 →	0.75 min ⁻¹	L1+L2 L3+L4 1 x 120 Nm 2 x 120 Nm	3 Ph	
HK max. = 190 m 6 - Lagen / 6 - layers / 6 - couches						
Type SR WB 66-100/4F 66.0 kW			→ 112 m / min	2 500 kg	→ 56 m / min	5 000 kg
			→ 70 m / min	4 200 kg	→ 35 m / min	8 400 kg
			→ 45 m / min	7 100 kg	→ 23 m / min	14 200 kg
			→ 28 m / min	10 000 kg	→ 14 m / min	20 000 kg
			Motorenleistung ges. Total motor output Puissance moteur (ohne/without/sans SR 10-190/3) ~ 150 kW			
			Anschlussleistung Connected power Puissance installée 280 kVA			

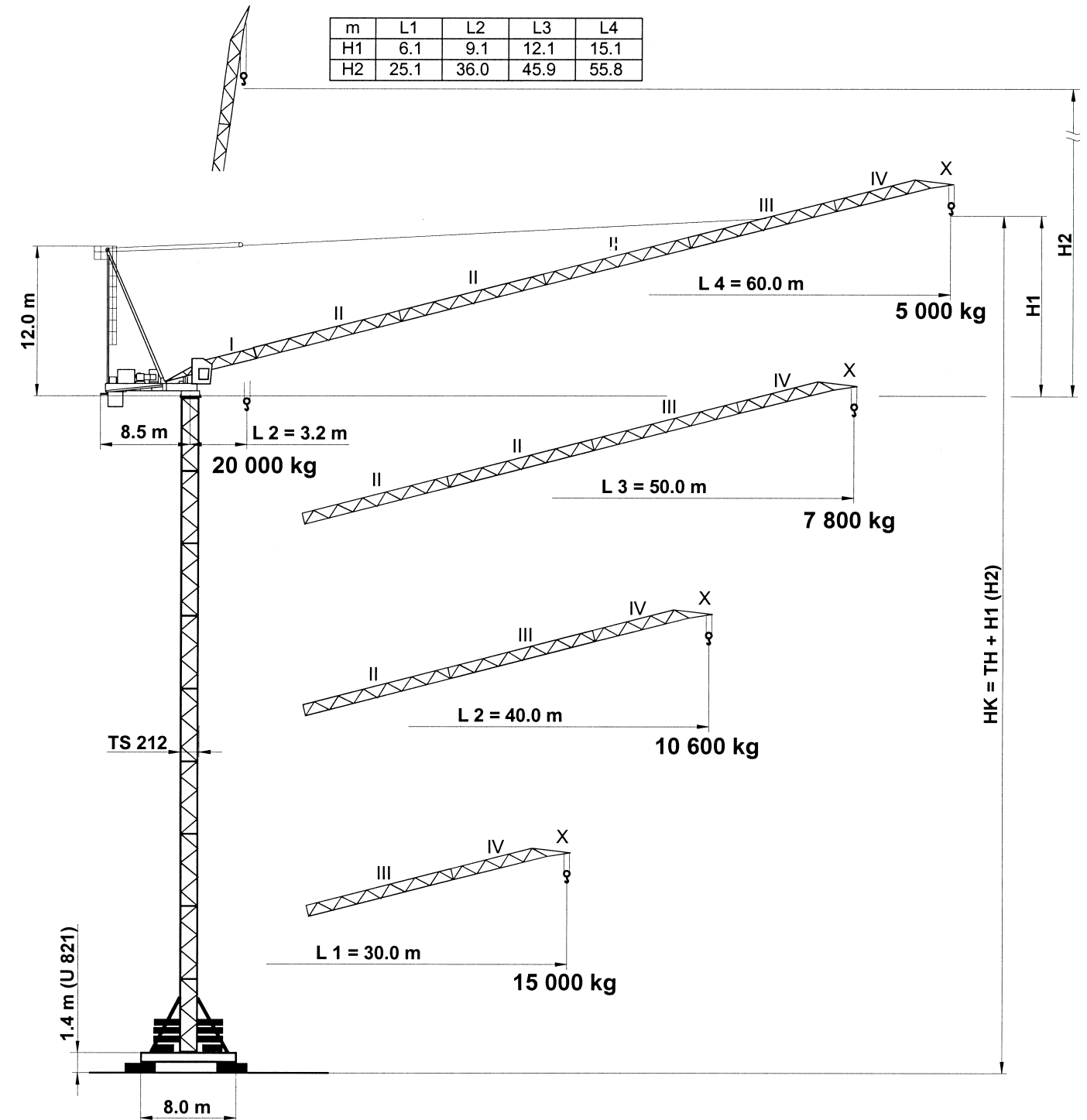

Unsere Vertretung:
Our representative:
Notre représentant:

TEREX PEINER GmbH
Gottbillstraße 1-7 · D-54294 Trier
Telefon: ++49 (6 51) 81 00 8 - 0
Telefax: ++49 (6 51) 8 93 00 u. 8 76 40
internet: <http://www.terex-peiner.de>
e-mail: info@terex-peiner.de



simple, available and cost effective™

DIN / FEM

Max. Tragfähigkeit
Lifting capacity
Force de levage

20.0 t

Turmversionen • Tower versions • Versions de tours

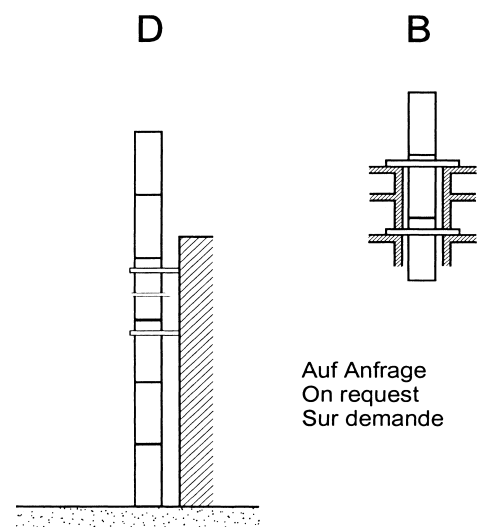
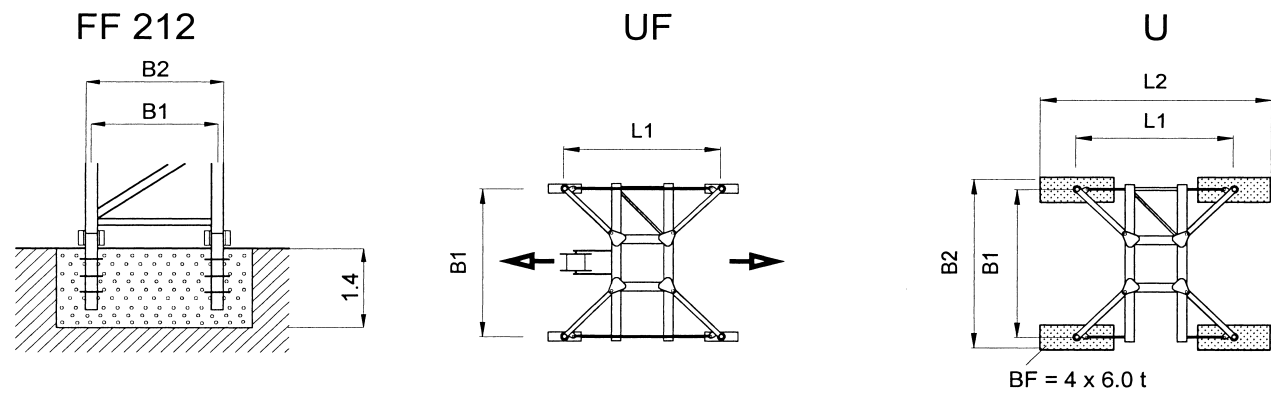
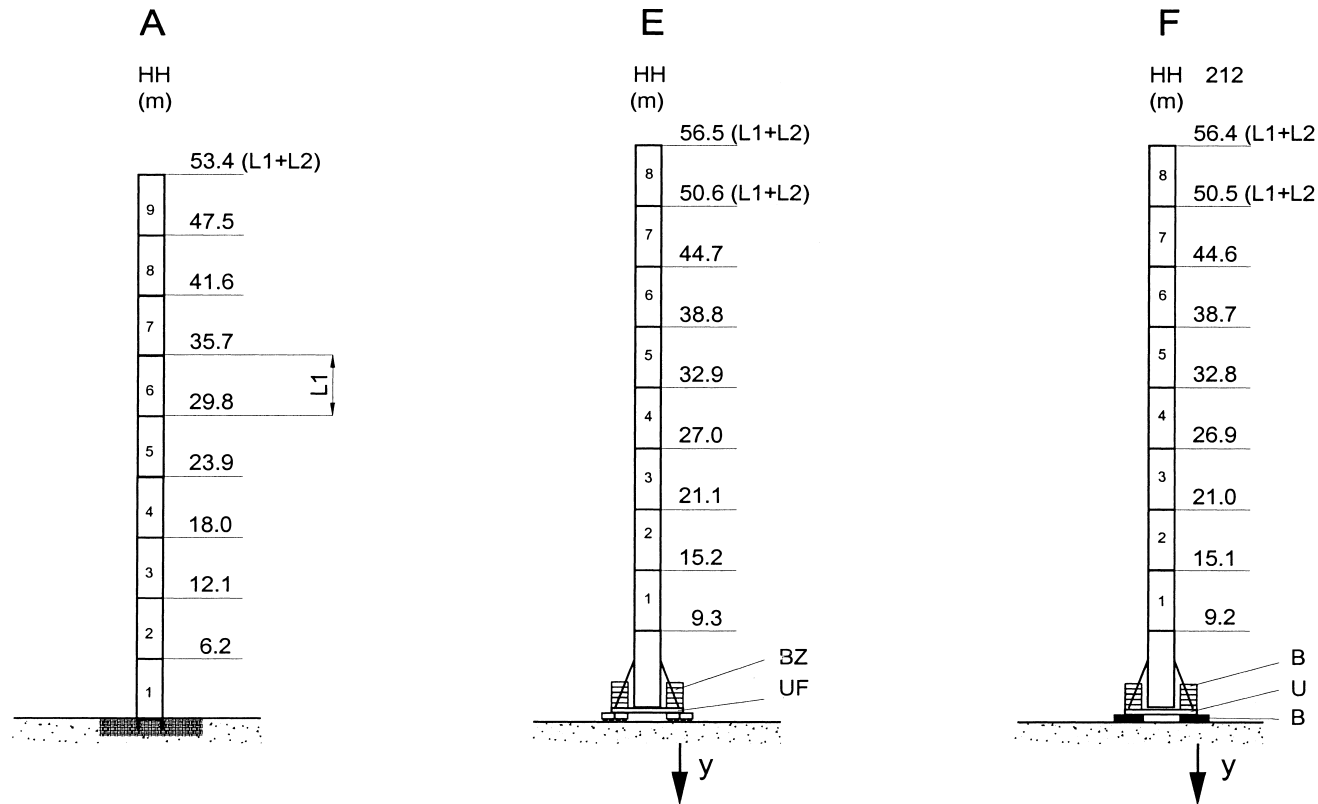

	B1	B2	L1	L2	y / ●	y / ■
	m				kN	
U 821	8.0	8.0	8.0	10.8	1082	1108
UF 821	8.0		8.0		1084	1153
TS 212.2	2.15	2.37	5.9			
TSV 212	2.15	2.37	7.9			
TSK 212	2.15	2.37	2.0			

● in Betrieb / in operation / en service
 ■ außer Betrieb / out of operation / sans service

Ausladung und Tragfähigkeit • Radius and capacity • Portée et charge

Ausleger / Jib / Flèche	Max. Tragfähigkeit / Max. Capacity / Charge max.	Ausladung (m) und Tragfähigkeit (t) / Radius (m) and capacity (t) / Portée (m) et charge (t)																
		20.0	23.0	25.0	30.0	31.4	35.0	39.5	40.0	42.5	45.0	47.5	50.0	52.5	55.0	57.5	60.0	
m	20.0 t	20.0	23.0	25.0	30.0	31.4	35.0	39.5	40.0	42.5	45.0	47.5	50.0	52.5	55.0	57.5	60.0	
L4 60.0																		
L3 50.0																		
L2 40.0	3.2 - 22.0 m	20.0	19.1	17.5	14.4	13.7	12.2	10.7	10.6									
L1 30.0	2.0 - 23.0 m	20.0	20.0	18.2	15.0													
m	10.0 t	20.0	23.0	25.0	30.0	31.4	35.0	39.5	40.0	42.5	45.0	47.5	50.0	52.5	55.0	57.5	60.0	
L4 60.0	5.8 - 31.4 m	10.0	10.0	10.0	10.0	10.0	8.9	7.8	7.7	7.2	6.8	6.4	6.1	5.8	5.5	5.2	5.0	
L3 50.0	4.5 - 39.5 m	10.0	10.0	10.0	10.0	10.0	10.0	10.0	9.9	9.3	8.7	8.2	7.8					
L2 40.0	3.2 - 40.0 m	10.0	10.0	10.0	10.0	10.0	10.0	10.0	10.0									
L1 30.0	2.0 - 30.0 m	10.0	10.0	10.0	10.0													

Ballastierung • Ballast • Lest

Version F – mit Zentralballast und Fundamentballast / with Central ballast block and Foundation block / avec Lest de base et Bloc de fondation – BZ + BF

HH (m)	9.2	15.1	21.0	26.9	32.8	38.7	44.6	50.5	56.4
U 821 - L1+L2 (t)	50.4	50.4	50.4	50.4	50.4	50.4	63.6	76.8	103.2
U 821 - L3+L4 (t)	50.4	50.4	50.4	50.4	50.4	76.8	90.0		

Version E – mit Zentralballast / with Central ballast block / avec Lest de base – BZ

HH (m)	9.3	15.2	21.1	27.0	32.9	38.8	44.7	50.6	56.5
UF 821 - L1+L2 (t)	39.6	39.6	39.6	39.6	52.8	66.0	79.2	92.4	92.4
UF 821 - L3+L4 (t)	39.6	39.6	39.6	52.8	66.0	92.4	92.4		

Gegengewichtsballast • Counterweight • Contrepoids

Ausleger / Jib / Flèche	L1	L2	L3	L4
	30.0	30.0	32.0	32.0
BG (t)			2 x 1.0	2 x 1.0
	6 x 5.0	6 x 5.0	6 x 5.0	6 x 5.0

SN 356/406 Transportmaße und Transportgewichte

Dimensions and weights of transport
Dimensions et poids pour transport

Montagegewichte siehe Betriebsanleitung!
Mounting weights see operating manual!
Poids de montage voir instruction de service!

	Benennung Designation Désignation		Abmessungen (m / ft) Dimensions (m / ft)			Gewicht Weight Poids t / kips	Volumen Volume m³ / ft³	
			l	b	h			
1	Ausleger / Boom / Flèche Schuss / Section / Élément I		6.03 19'-9"	2.25 7'-5"	1.79 5'-10"	1.64 3.6	24.29 85.84	
2	Ausleger / Boom / Flèche Schuss / Section / Élément II		10.52 34'-6"	2.22 7'-3"	1.76 5'-9"	1.54 3.4	41.10 145.24	
	Schuss / Section / Élément L1 - L2		10.52 34'-6"	2.22 7'-3"	1.76 5'-9"	1.39 3.1	41.10 145.24	
	Schuss / Section / Élément L2 - L3		10.52 34'-6"	2.22 7'-3"	1.76 5'-9"	1.32 2.9	41.10 145.24	
	Schuss / Section / Élément L3 - L4		10.52 34'-6"	2.22 7'-3"	1.76 5'-9"	1.35 3.0	41.10 145.24	
	Schuss / Section / Élément III		10.64 34'-11"	2.22 7'-3"	1.85 6'-1"	1.66 3.6	43.70 154.42	
3	Ausleger / Boom / Flèche Schuss / Section / Élément IV		6.75 22'-2"	1.71 5'-7"	2.10 6'-11"	1.19 2.6	24.24 85.66	
4	Drehbühne mit DA und Drehwerk Turntable with DA and slewing gear Plateforme tournante avec DA et mécanisme de giration		4.02 13'-2"	2.54 8'-4"	2.35 7'-9"	13.4 29.5	24.00 84.80	
5	Gegenausleger Counter jib Contre flèche		6.02 19'-9"	2.22 7'-3"	1.52 5'-0"	6.88 15.2	20.30 71.68	
6	Kabine mit Podest, Geländer, Schaltschrank Cabin with support, railing, electrical panel Cabine avec appui, garde corps et armoire électrique		6.32 20'-9"	1.90 6'-3"	2.30 7'-6"	2.78 6.1	27.62 97.53	
7	Bockspitze mit Leiter A-frame with ladder A-cadre avec échelle		11.70 38'-5"	2.09 6'-10"	0.98 3'-3"	4.47 9.9	23.96 84.60	
8	Hubwinde mit Seil 66WB Hoist winch with rope Mécanisme de levage avec câble		1.90 6'-3"	2.51 8'-3"	1.21 4'-0"	4.10 9.0	5.77 20.37	
9	Verstellwinde mit Seil 66WB Luffing winch with rope Mécanisme de relevage avec câble		2.95 9'-8"	2.11 6'-1"	1.21 4'-0"	3.43 7.6	7.53 26.59	
10	Gegengewichtsballast Counterweight ballast Contrepoids	BG	1.0 t	1.7 5'-7"	0.14 0'-5"	2.28 7'-6"	1.00 2.2	0.54 1.90
			5.0 t	1.7 5'-7"	0.44 1'-5"	3.08 10'-1"	5.00 11.0	2.30 8.12
11	Ballastwagen Counterweight carriage Chariot de contrepoids		5.52 18'-1"	0.90 2'-11"	1.33 4'-4"	1.34 2.9	6.61 23.34	
12	Turmschuss Tower section Élément de tour	mit Streben with struts avec étançons	TS 212.1	5.95 19.52	2.37 7.78	2.45 8.01	4.14 9.13	34.4 1216
			TSV 212.1	9.50 31.17	3.00 9.84	3.05 10.00	9.22 20.33	86.9 3067
13	Fundamentkreuz, kurvenfahbar, geklappt Cruciform base, folded Croix de fondation, mobile, replié	U 821	12.5 41.01	2.97 9.74	2.15 7.05	15.90 35.10	79.8 2816	
14	Fundamentkreuz, stationär, geklappt Cruciform base, railgoing, folded Croix de fondation, replié	UF 821	10.53 34.55	2.76 9.06	0.85 2.79	7.77 17.10	24.7 873	
15	Zentralballaststein Central ballast block Bloc de fondation	BZ	4.50 14.77	2.05 6.73	0.40 1.31	6.60 14.55	3.7 130	
16	Fundamentblock Foundation pad Bloc de fondation	BF	3.00 9.84	1.20 3.94	0.75 2.46	6.00 13.22	2.7 95	
17	Diverse Montageteile Accessories Accessoires							